



## Wakely 510 Model Crimper /Dry Roller

- High quality precision balanced Solid Chilled Rollers 510 / 300dia
- Working surface of Rollers are 50 - 54 Rockwell hardness
- Output per hour: Crimped 10 - 12 tonne. Dry Rolled 6 - 8 tonne
- Gear driven rollers
- Belt drive to Auger & Elevator
- Double row spherical Roller Bearings
- No metal to metal contact between rollers
- 2.5 tonne feed hopper
- Sound suppression pads

### Mobile Option

The Wakely Crimper is a further development of our very successful range of Industrial and Farmers Mills. Synonymous with durability for over 25 years all our mills feature Solid chilled Rolls. The rolls are solid chilled, made by the centrifugal casting process and use a double pour technique. They cannot be compared with mild or hardened steel rolls and with annual maintenance, chilled rolls last indefinitely. The rolls are balanced to a degree that vibration is almost eliminated and with the inclusion of sound deadening pads leads to any extremely low noise, low vibration machine, thus extending mill life and improving the working environment

**WAKELY ENGINEERING LIMITED, ESSEXFORD, LOUTH, DUNDALK, CO. LOUTH, IRELAND**

Tel: 00353 (0)42 9374388 Fax: 00353 (0)42 9374669 Email: [info@wakelyengineering.ie](mailto:info@wakelyengineering.ie) Web: [www.wakelyengineering.ie](http://www.wakelyengineering.ie)

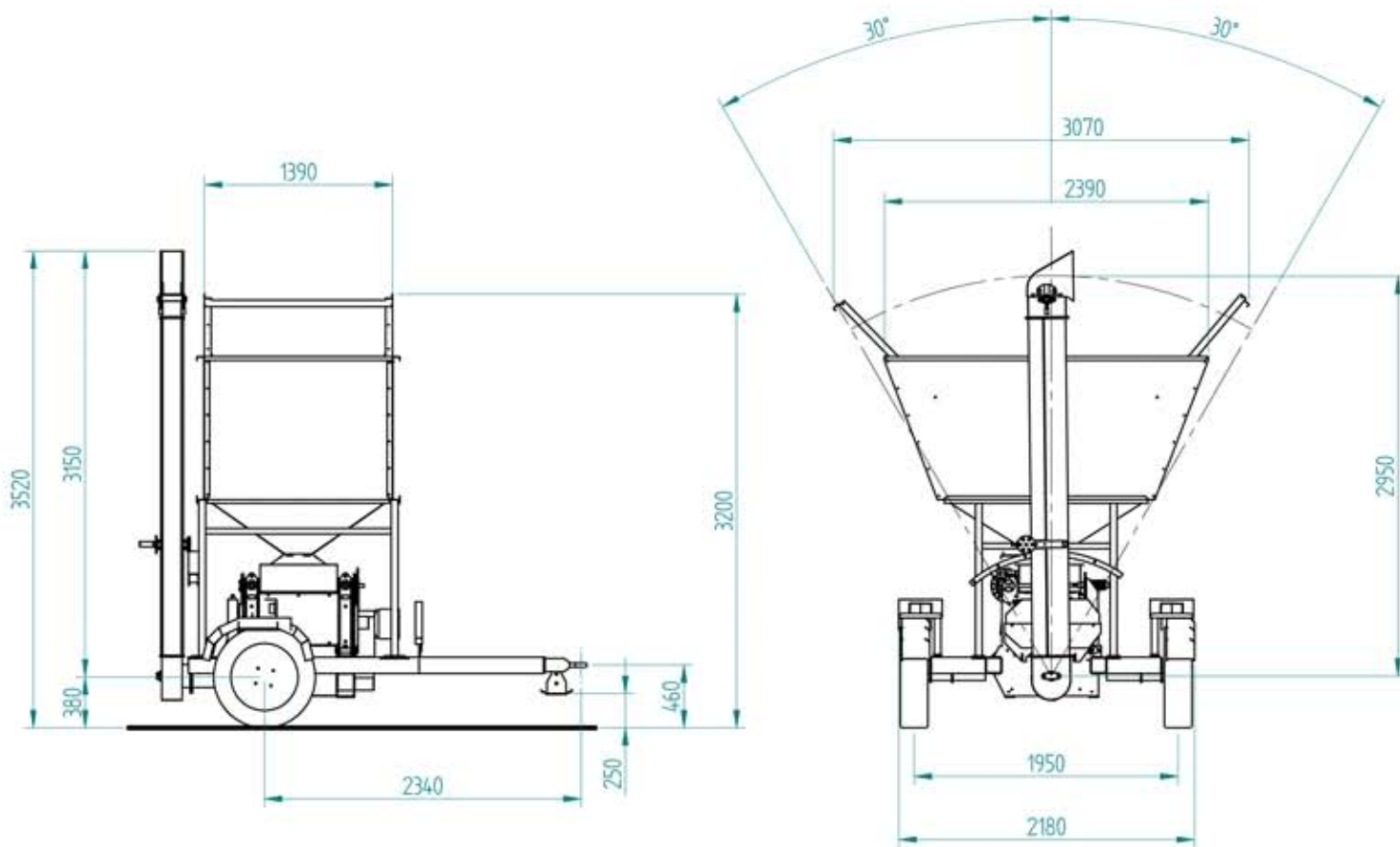

Adjustment made simple with the Unique Wakely Parallel roll gap adjustment lever.



Feed Spreader Flap: Ensures a continuous even flow of feed.

The Wakely Crimper can be filled with a front-end loader or loading shovel. The crushed grain from this Mill is removed from underneath the machine using a combination of a U Trough Auger mounted underneath the Mill, this moves the crushed grain from underneath the Mill to the bottom of the Elevator. The grain is then elevated to approx. 4 meters high and can then be fed into a trailer or Silo. The rolls are mounted on high quality 70mm double roll spherical roller bearings in a plummer block unit. Discharge Auger driven by belt and pulleys.

## WAKELY ROLLER/CRIMPER MILLS - THE YELLOW ONES THAT EVERYONE IS TALKING ABOUT!

### UNIQUE WAKELY FEATURES:

- Precision balanced chill hardened SOLID rollers - Working surfaces are 50-54 Rockwell hardness - Double row spherical roller bearings
- Grease immersed gear drive between rollers - Smooth running LOW NOISE efficient rollers with no roller to roller contact
- Simple parallel roll gap adjustment with single levers - NO SPANNERS!!

WAKELY MILLS AS SUPPLIES TO THE FARMING AND MILLING INDUSTRY FOR OVER A QUARTER CENTURY

"REVOLUTIONARY SOLID EDGE TECHNOLOGY IS USED IN THE DESIGN AND MANUFACTURING PROCESS OF THE WAKELY RANGE OF ROLLERS"

Anything you can combine a Wakely Mill can crush - "SUPPLIERS TO THE LEADING MILLERS AND CONTRACTORS ON THE IRISH AND UK MARKET"